

**Deburring Instruction
Manual
Program Specifications**

Murata Machinery, Ltd.

Contents

Chapter 1	Outline.....	1
Chapter 2	Available M codes	2
Chapter 3	Program format	3
Chapter 4	Machining program precautions	5
Chapter 5	Workpiece holder safety zone	9
Chapter 6	Typical program example	10

Chapter 1 OUTLINE

This document describes the format of machining programs, machining order and precautions when performing deburring using the ball tool.

Read and thoroughly understand the content of the "Ball Tool Machining Specifications" (separate manual) so that you can create machining programs correctly.

As shown in Chapter 3 "Program Format," when the scribing tool mode instruction programmed between M codes M326 and M325 is additionally executed within the Wilson mode that is already programmed between M codes M321 and M320, deburring can be achieved by programming the ball tool mounted at the fixed station to travel on the XY table with the BDC (bottom dead center) stroke instructed in die parameters maintained at a fixed stroke.

Chapter 2 AVAILABLE M CODES

M Code	Description	Remarks
M321	Wilson mode ON	
M320	Wilson mode cancel	
M326	Scribing tool mode ON	
M325	Scribing tool mode cancel	
M21	Exact stop/check mode	
M1***	Call die parameters	**** indicates the die parameter No.
M1000	Call die parameters cancel	

Chapter 3 PROGRAM FORMAT

Maintain the following programming order of M codes in the program.

~

M321

M326

T08

M1200

Call die parameter No.200 (No.200 may be any number.)

M21

Exact stop/check mode

PDR/X__Y__D2

Line offset instruction (D2)

Or

PDL/X__Y__D2

X__Y__F__

Line machining at F speed

PED/

Temporary return to TDC is necessary to change ram BDC position.

M1201

Call die parameter No.201 (No.201 may be any number.)

PDR/X__Y__D3

Curved line offset instruction (D3)

Or

PDL/X__Y__D3

CIR/X__Y__F__

Arc machining at F speed

PED/

Temporary return to TDC is necessary to change ram BDC position.

M1200

Call die parameter No.200 (No.200 may be any number.)

PDR/X__Y__D2

Line offset instruction (D2)

Or

PDL/X__Y__D2

X__Y__F__

PED/

Temporary return to TDC is necessary to change ram BDC position.

M325

M320

M620

TDC mode cancel (If this instruction is not programmed, all subsequent punching will be executed from the top dead center, and the machining time becomes slower.)

M1000

Call die parameters cancel

~

PDR/X__Y__Dn n=2 to 36

Or

PDL/X__Y__Dn

- For Dn, the tool offset No.n set in the machine's NC is looked up. The machining locus is offset by the numerical value [mm] registered to tool offset No.n.
- Laser machining instructions can be used between programmed PDL or PDR and PED. For details, refer to the Laser Machining Programming Manual.

Main laser machining instructions:

Xa Yb	Linear interpolation (absolute)
DXa Dyb	Linear interpolation (incremental)
CIR/Xa Yb θ	Circular interpolation
LCI/L a b r	Circular interpolation
LHS/~LHE	Circular interpolation

Chapter 4 MACHINING PROGRAM PRECAUTIONS

1. Micro Joint Machining

- (1) The machining locus (track center coordinates) that the ball tool travels along is positioned by a certain offset (α mm) from the outer periphery line or inner periphery line.

* The value registered to the tool offset value n address in the NC specified by PDL/X_Y_Dn or PDR/X_Y_Dn is used as α mm.

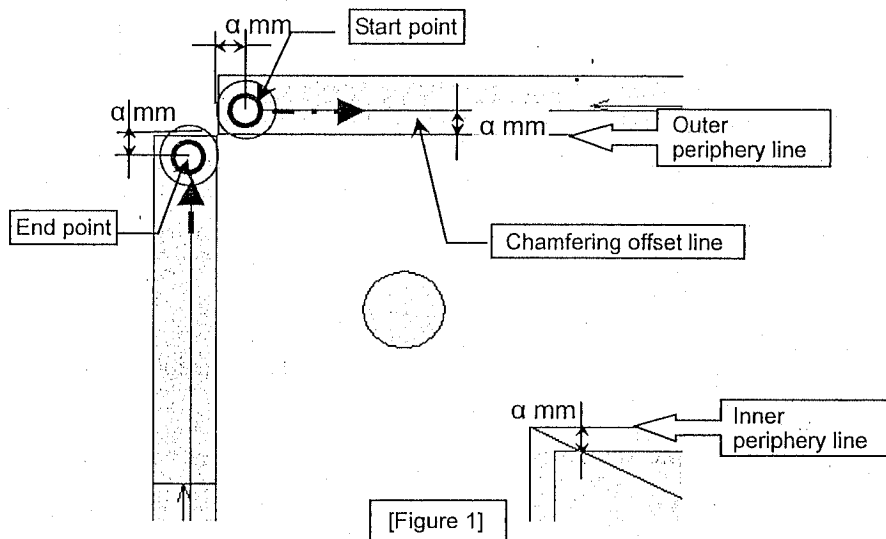

- (2) Set a point 2 mm from a corner as the start point for the ball tool.
Also, set a point 2 mm in front of the product corner as the end point.

Otherwise, this will lead to disjuncting of micro joints or ball tool damage.

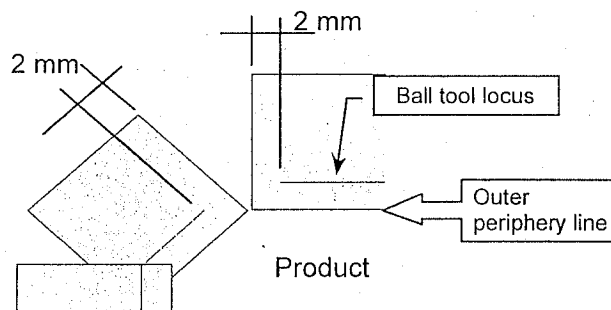

- (3) Set start and end points for corner window drilled sections 2 mm away from corners.

If machining is not started or ended from points 2 mm away from corners, knock marks will be caused by the ball tool striking the product, or the ball tool might become damaged.

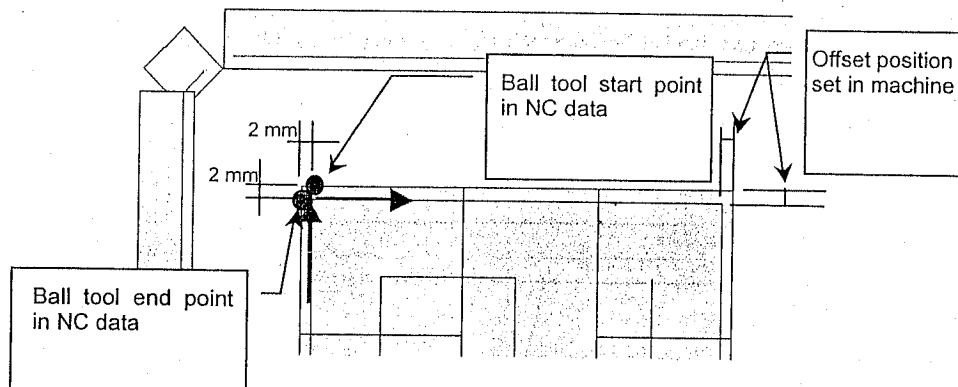

- (4) Do not pass the tool over lozenge-shaped joints or wire joints. (See figure below.)

Doing so will lead to disjuncting of micro joints or ball tool damage.

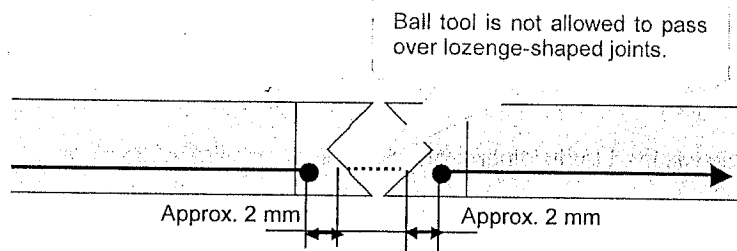

(5) Change the machining conditions and perform bottom side chamfering according to the location to be deburred.

<Test conditions>

- Machine M2048LT
- Workpiece material SPCC1.2^t

* Use the above numerical values as reference values.

Location to be Deburred	Offset	Feed Rate	BDC	Location to be Deburred (in figure below)
Circles	1.5	F300	-3.00	①
Arcs	1.5	F300	-3.00	(①)
Square holes	2.0	F500~5000	-3.20	②
Outer periphery	2.0	F500~5000	-3.20	③

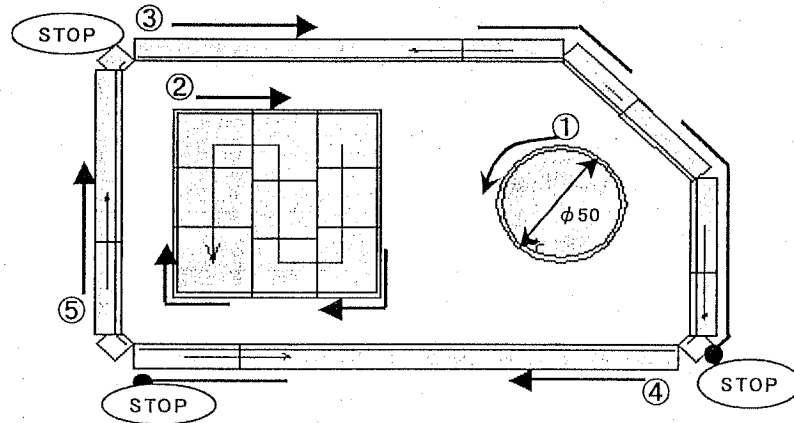

(6) Recommended machining order

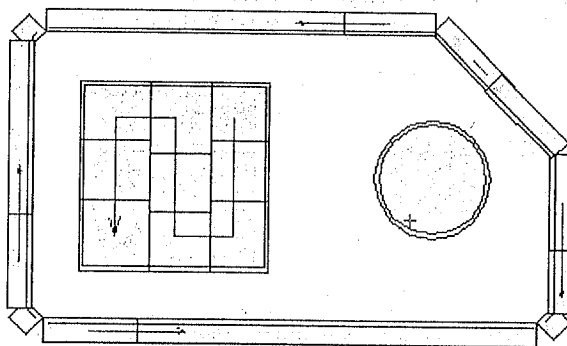
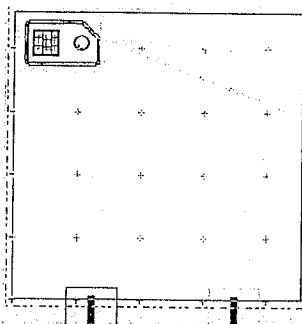

Machining Order	Location to be Deburred	Example of Used Tool
N=30	Slotted-hole machining (round, square hole)	$\phi 10$, $\phi 20$, $\square 20 \times 20$
	Corner chamfering	$\diamond 10 \times 10$
N=31	Slotted-hole machining (deburring of round and square hole sections)	Ball tool
N=40	Vertical cutting	5x40
	Diagonal outer periphery cutting	40x5 (IT)
N=41	Horizontal cutting	80x5, 40x5 (IT)
N=42	Deburring of outer periphery machined sections	Ball tool
N=50	Forming (burring, embossing)	Burring (up/down), embossing
N=51	Tapping	4-axis tapping unit

Chapter 5 WORKPIECE HOLDER SAFETY ZONE

Standard workpiece holder

X 125mm

Y 93mm

Loader specification workpiece holder

X 139mm

Y 93mm

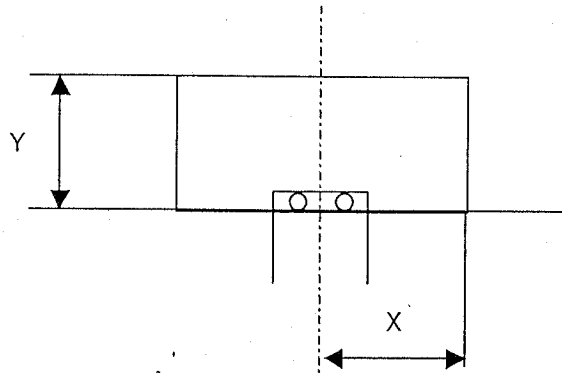

As the ball tool is lowered during ball tool machining, the safety zone includes an overshoot distance up to where the tool comes to a stop during machining at a maximum travel speed of 50 m/min.

For this reason, the workpiece holder safety zone is larger than the workpiece safety zone of a regular tool.

Chapter 6 TYPICAL PROGRAM EXAMPLE

```

%
02202
MAT/B4H1.6X915Y915
(OMOTE1 SECC      ZZZTEMP      )
(/X= 915.0000 Y= 915.0000 TH= 1.6000)
(/WHP1= 250.0000 WHP2= 700.0000)
(/STA.NO  TL.NO  STYLE  SIZE1  SIZE2  ANGLE)
(/T0500D  M0624 CIRCLE  50.00  0.00  0.00)
(/T0800B  M0446 WHEEL T   1.00  0.00  0.00)
(/T1100B  M0783 RECTANG  10.00  10.00  45.00)
(/T1200D  M0918 RECTANG  30.00  30.00  0.00)
(/T1500I  M0980 RECTANG  40.00  10.00  0.00)
OFS/X39.43Y757.39
PAT1/
X222.18Y0.11T11
X-2.18
Y119.89
END1
MGR1/1 R 245 2
PAT1/
X170Y60T05
END1
MGR1,1
PAT1/
X85Y85T12
GRD/D 25 2 L 25 2
END1
MGR1,1

M321
M326
PAT1/
T08
M1201
M21

```

PDR/X170Y85D3
CIR/170 60 360 F100
PED/

M1200
PDR/X20+2Y100D2
X100-2F1500
Y20+2
X20+2
Y100-2
PED/
END1
MGR1,1
M325
M320
M620
M1000

PAT1/
MOV/X220Y71T15C90
REC/D 67 40 37 10
MOV/X-10Y4
REC/U 112 40 37 10
END1
MGR1,1

PAT1/
X186.97Y110.1T15C315
LAA/32.71 315 1
END1
MGR1,1
PAT1/
MOV/X171Y120T15C0
REC/L 165.85 40 37 10
MOV/X5.15Y-10
REC/R 209.7 40 37 10
END1
MGR1,1

M321
M326
PAT1/
T08
M1200
M21
PDL/X7Y120D2
X170F500
X220Y70
X220Y5
X217.83Y0
PED/
M1200
PDL/X213Y-2
X7Y-2F500
PED/
M1200
PDL/X2.17Y0
X-2Y5F500
X-2Y115
X2.17Y120
PED/
END1
MGR1,1
M325
M320
M620
M1000
OFS/X0Y0
X2500Y1250M30
%

First Version October, 2005

Revised November, 2005 (M21 added)

Revised February, 2006 (safety zone added)

Note that the content of this document is subject to change without notice accompanying improvements to the product.

Also, note that the photographs and drawings used in this document also are subject to change without notice.

**Deburring Instruction
Manual
Machining Specifications**

Murata Machinery, Ltd.

Contents

Introduction	1
Chapter 1 Machining principles	2
Chapter 2 About the tool used	3
Chapter 3 Ball tool compatible machines	4
Chapter 4 Workpiece materials compatible with ball tool	4
Chapter 5 Reference bottom dead center strokes of ball upper die.....	5
Chapter 6 Reference ball traverse speeds	6
Chapter 7 Reference micro joint widths.....	7
Chapter 8 Workpiece holder safety zone	8
Chapter 9 Parts that cannot be chamfered from bottom side	9
Chapter 10 Machining limitations with ball tool.....	11

Introduction

This document describes machined locations that are deburred using the ball tool made by Murata Tools, Ltd. and limitations in deburring quality. (Burrs occur during sheet punching.) Fully understand the features and limitations of ball tools before using the ball tool.

"Deburring" described in this document refers to the process of deburring by press forming from both above and below, and deburring quality is defined as a clearance of about 0.2.

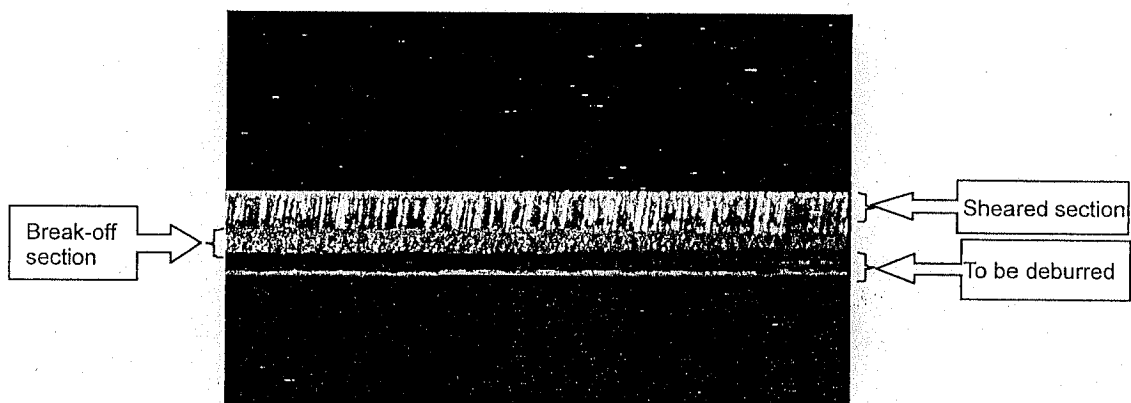

Chapter 1 MACHINING PRINCIPLES

What is a "ball tool?"

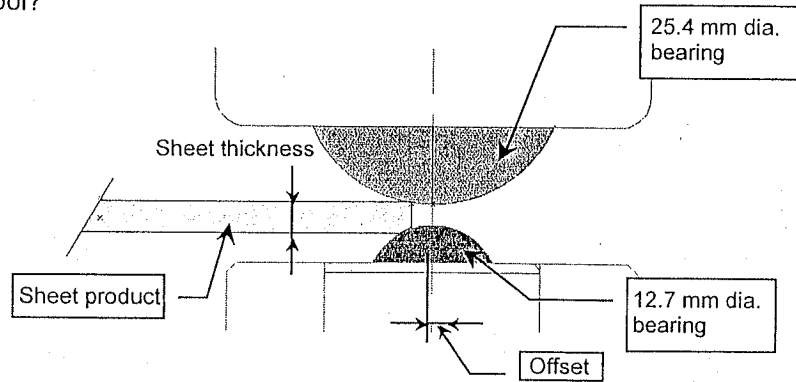

The ball tool comprises two bearings, a 25.4 mm dia. bearing in the upper die and a 12.7 mm dia. bearing in the lower die. The tool is made to pass along a locus above the locations to be deburred to remove burrs from the rear side of the product.

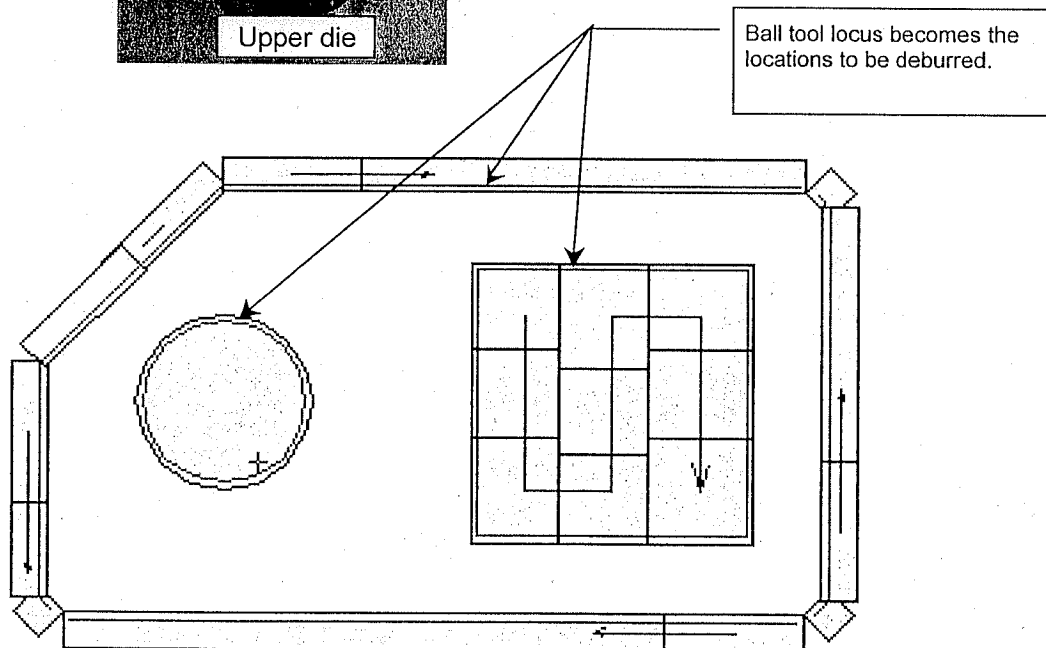
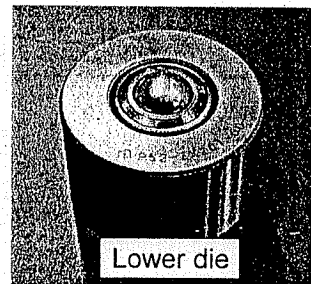

Chapter 2 ABOUT THE TOOL USED

The following shows the structure of the ball tool.

The range used is station range B.

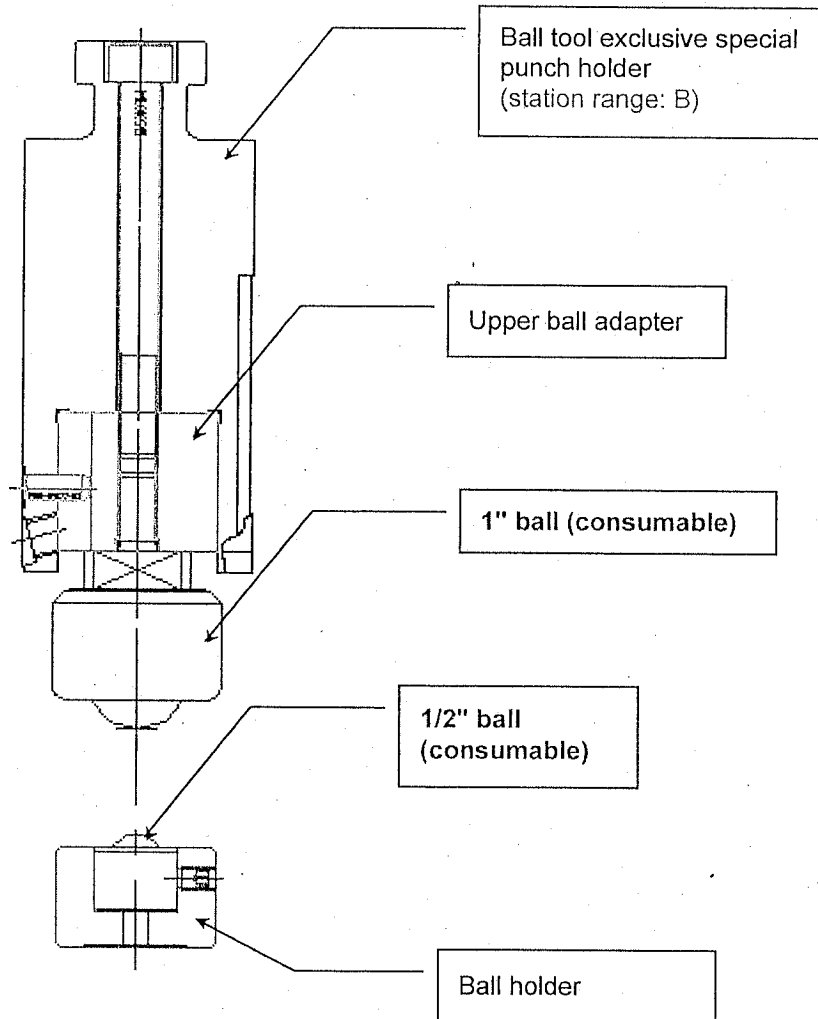

The ball tool may be mounted in either the in or out track inside the turret.

When rotation of the free-rotating ball bearing worsens, replace only the 1" ball or the 1/2" ball.

Order ball tools from your dealer or Murata Tools, Ltd.

Chapter 3 BALL TOOL COMPATIBLE MACHINES

- Motorum series Motorum 2048LT or later

Some machines do not support the ball tool option depending on the production date.

For details of option support, contact your dealer.

- NPS-01
- Machines that have the Wilson tool control support option
- CAMPATH-G4 Ver.1.08 or later

The ball tool is not supported on CAMPATH2000.

Chapter 4 WORKPIECE MATERIALS COMPATIBLE WITH BALL TOOL

Material	SPCC, SPHC, SUS304, SUS430, SECC, AL
Sheet thickness	Soft steel plate: 0.8 mm (min.) to 3.2 mm (max.) Stainless steel: 0.8 mm (min.) to 2.0 mm (max.)

Chapter 5 REFERENCE BOTTOM DEAD CENTER STROKES OF BALL UPPER DIE

The table below lists reference bottom dead center (BDC) strokes for a tool of length 177.0 mm.

Sheet Thickness	BDC
0.8t	-3.5
1.0t	-3.7
1.2t	-3.9
1.6t	-4.3
2.3t	-5.0
3.2t	-5.6

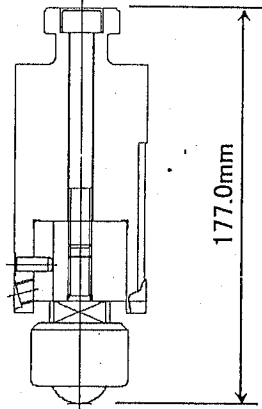

The above test values were obtained on a Motorum 2048LT.

Numerical values sometimes differ on other machines or on Motorum machines due to assembly error.

Chapter 6 REFERENCE BALL TRAVERSE SPEEDS

Change the deburring traverse speed according to the shape of the location to be deburred.

The traverse speed can be changed by F codes in the machining program.

(For details, see the machining program data.)

[cm/min]

Location to be Deburred	Machining Speed F
Long line locations (straight lines in X direction) *1	5000 max.
Long line locations (straight lines in Y direction) *1	5000 max.
Long line locations (diagonal straight lines) *1	5000 max.
Notches or notched sections 10 mm or less	500 max.
Curved line locations (e.g. circles or arcs)	300 max.

*1) "Long" refers to a traverse length of about 100 mm or more.

Chapter 7 REFERENCE MICRO JOINT WIDTHS

As described in "Chapter 1 Machining Principles," the ball tool travels along a locus above the locations to be deburred.

As the ball tool travels with the workpiece material pressed between two balls near micro joints, the danger of the micro joints disjoining during deburring increases if a micro joint width matched to the material and sheet thickness is not ensured.

Sheet Thickness	Material	Die Clearance	BDC	Micro Joint Width
SPCC	0.8t	0.15	-3.5	0.2
SPGC	1.0t	0.2	-3.7	0.2
SECC	1.2t	0.2	-3.9	0.2
SECC	1.6t	0.35	-4.3	0.15
SECC	2.3t	0.5	-5.0	0.15
SPCC	3.2t	0.7	-5.6	0.1

*) The above evaluation results were obtained on a test machine, Motorum 2048LT Brush Table Machine.

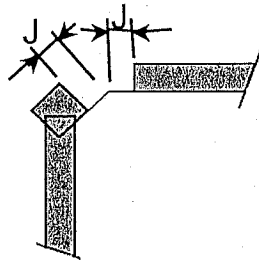

J=Micro joint width

Chapter 8 WORKPIECE HOLDER SAFETY ZONE

Standard workpiece holder

X 125 mm

Y 93 mm

Loader specification workpiece holder

X 139 mm

Y 93 mm

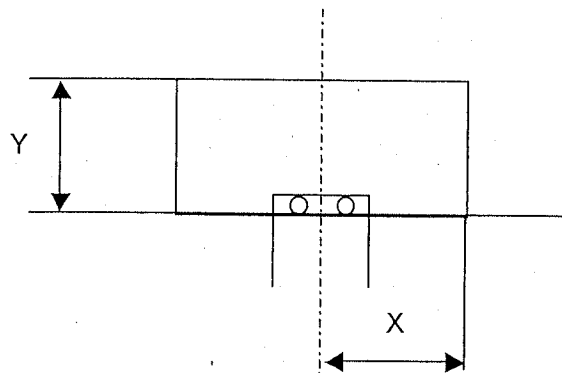

As the ball tool is lowered during ball tool machining, the safety zone includes an overshoot distance up to where the tool comes to a stop during machining at a maximum travel speed of 50 m/min.

For this reason, the workpiece holder safety zone is larger than the workpiece safety zone of a regular tool.

Chapter 9 PARTS THAT CANNOT BE CHAMFERED FROM BOTTOM SIDE

Make the ball tool travel along positions that are offset by a certain offset (α mm) from the line (locus) above the locations to be deburred.

Also, when making the ball tool travel from the start point to the end points, allow a distance offset by a certain offset (α mm) from the corners of the product. (See Figure 1.)

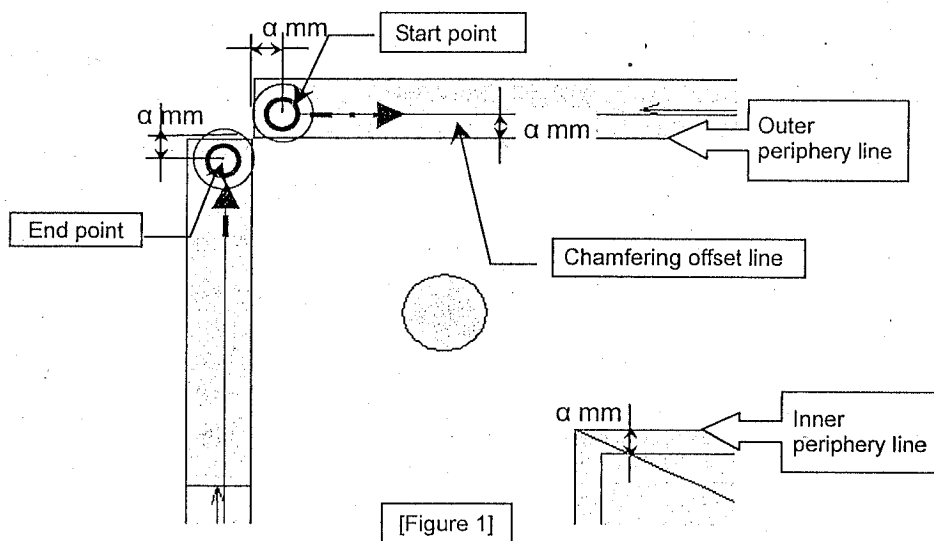

For this reason, the ball tool cannot deburr micro joint locations, corners of corner window drilled sections and notched sections.

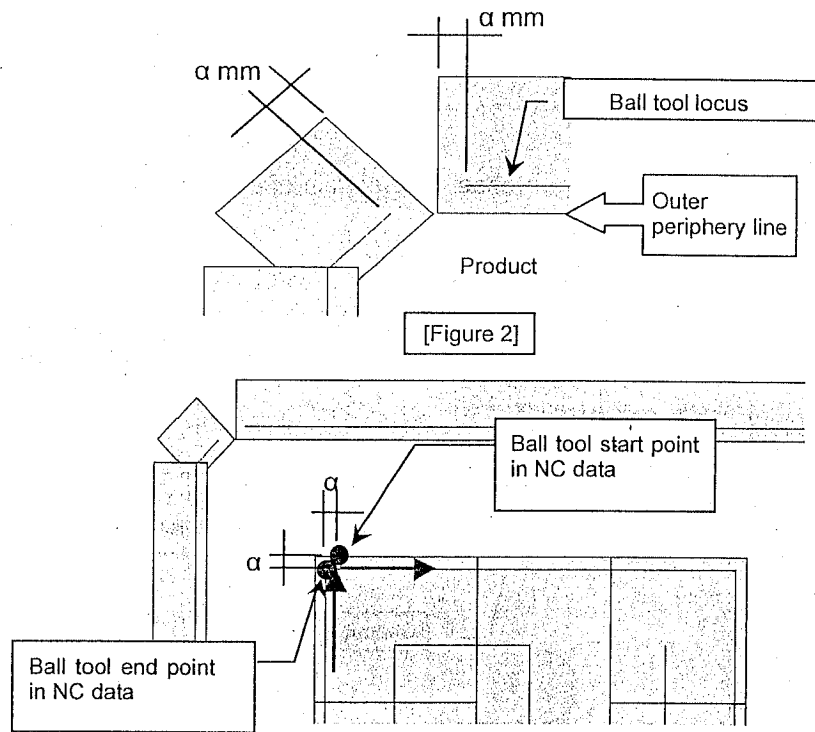

The following describes actual machining limitations due to the above limitations.

Chapter 10 MACHINING LIMITATIONS WITH BALL TOOL

(1) Deburring of parts having a slit width of 5 mm or less is not possible.

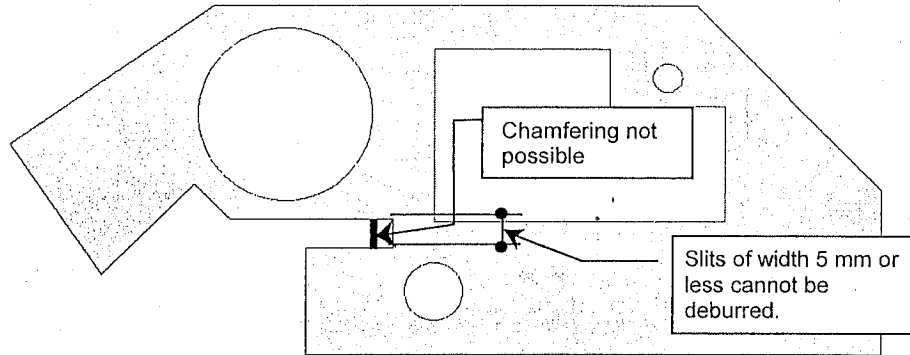

(2) Deburring near micro joint sections is not possible.

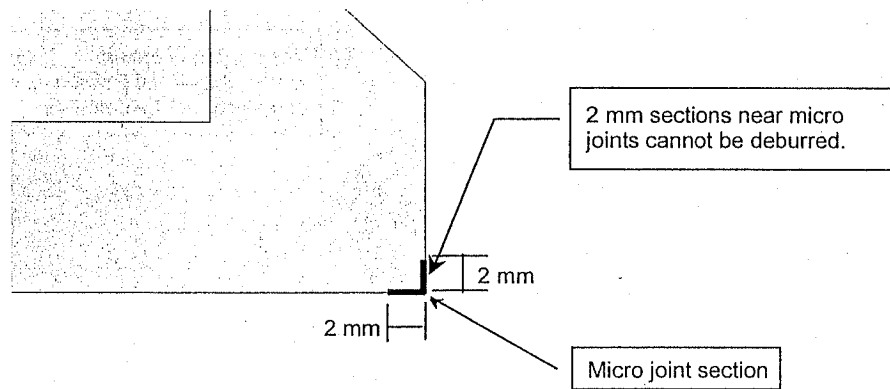

(3) Deburring of window hole corner sections is not possible.

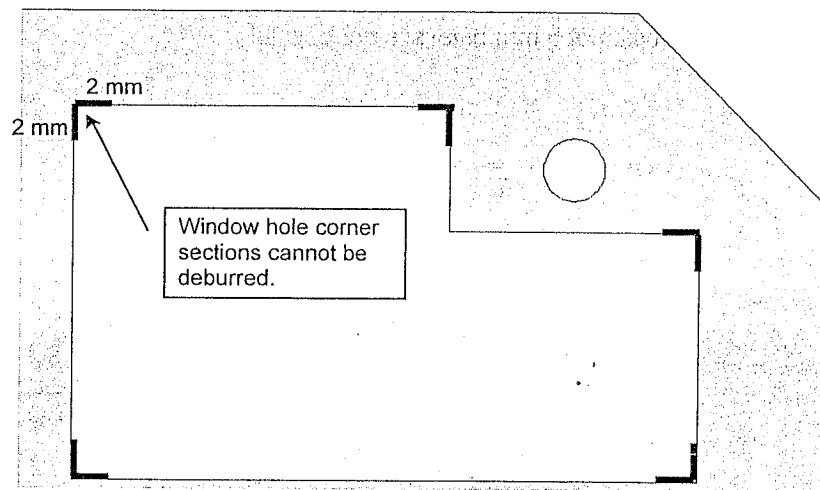

(4) Deburring of small punched holes of diameter 5 mm or less is not possible.

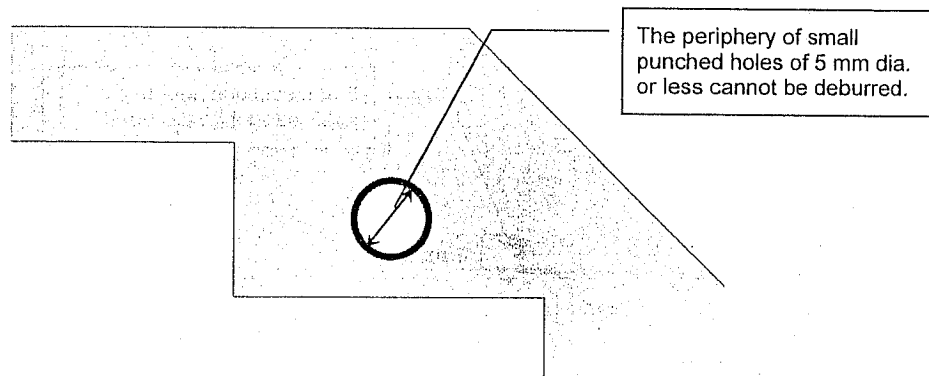

(5) Deburring of last cut parts for the FG loader is not possible.

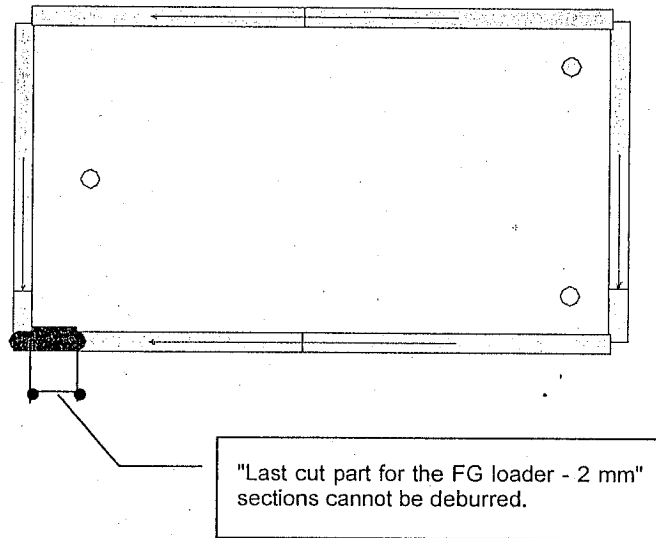

(6) When a discard tag for suction contact has been attached for FG loader feed out, deburring of micro joint sections is not possible.

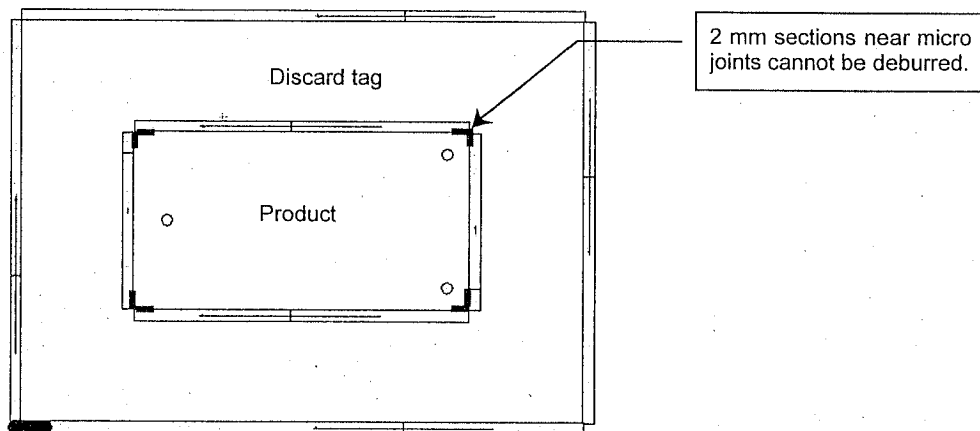

(7) Deburring of two locations, final cut section and next to final cut section, of products to be discharged from the chute is not possible.

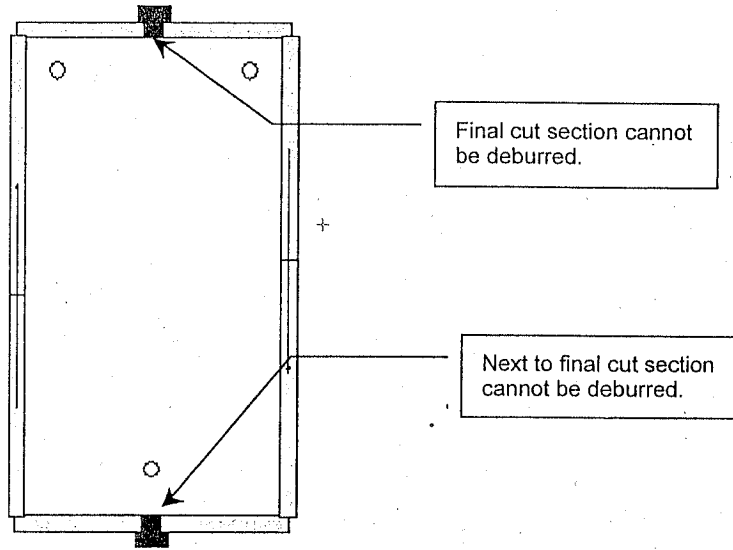

First Version October, 2005

Revised November, 2005
(sheet thickness specifications and compatible
machines changed)

Revised February, 2006 (safety zone added)

Note that the content of this document is subject to change without notice accompanying improvements to the product.

Also, note that the photographs and drawings used in this document also are subject to change without notice.