

Programming Manual

For
C3000/M5000 Punch Presses

Using

IC100/OMNICUT/MW150 Plasma Units

Notice

Murata Wiedemann, Inc. provides all data necessary for the proper instruction, test, operation and maintenance of its products. Murata Wiedemann, Inc. retains all proprietary rights in and to the information so disclosed and such shall not be reproduced, copied, or used in whole or in part for purposes other than those for which it is furnished.

We reserve the right to revise these specifications and information without prior notice.

Information in this document is subject to change without notice.

MURATA WIEDEMANN, INC.
10510 Twin Lakes Parkway
Charlotte, NC 28269

TABLE OF CONTENTS

PARAGRAPH	TITLE	PAGE
CHAPTER ONE	GENERAL	1-1
1.0	Safety	1-1
2.0	General	1-2
2.1	Dimensions	1-2
3.0	Torch Locations	1-2
3.1	C3000	1-2
3.2	M5000	1-4
CHAPTER TWO	PROGRAMMING	2-1
1.0	General	2-1
2.0	Workholder Safety Zones	2-1
3.0	Kerf Offset	2-2
3.1	Example Offset	2-2
4.0	Plasma Commands	2-3
4.1	PDL	2-4
4.1.1	Command Structure	2-4
4.2	PDR	2-4
4.2.1	Command Structure	2-4
4.3	PED	2-4
4.3.1	Command Structure	2-4
5.0	Cutting (Table) Feedrates	2-5
6.0	Motion Commands	2-5
6.1	Linear Command	2-5
6.2	Circular Command	2-5
6.2.1	CIR (Circle)	2-5
6.2.2	Command Structure	2-5
6.2.3	Examples	2-6
7.0	M5000 Track Changes	2-7
CHAPTER THREE	SAMPLES	3-1
1.0	Sample Program (Inch)	3-1
1.1	Sample Program Description	3-2
1.2	Sample Program Piece Part (Inch)	3-5
2.0	Sample Program (Metric)	3-6
2.1	Sample Program Piece Part (Metric)	3-7
CHAPTER FOUR	PLASMA ALARMS	4-1
1.0	Plasma Alarm List	4-1

GENERAL

1.0 SAFETY

When Plasma or Laser burning any material other than a mild steel containing a low carbon content, a potential toxicity and/or explosion hazard could arise. While we have attempted to design our equipment to be as safe as possible, we cannot predict in advance the degree of hazard, if any, which may be associated with the burning of a particular material by an individual customer. Therefore, prior to burning any material other than mild steel, we recommend that each customer should undertake a thorough investigation of any potential hazard which may be created by the burning of that material. Principal responsibility for this task must be the customers as each machine user only knows his particular circumstances.

The following organizations can be of assistance when investigating whether a hazard exists for a given application:

- American conference of Governmental Industrial Hygienists
6500 Glenway, Bldg. D-7
Cincinnati, OH 4521

- National Fire Protection Association
Batterymarch Park
Quincy, MA 02269

- Regional O.S.H.A. Office

2.0 GENERAL

This manual describes the basic programming instructions for plasma equipment, specified on the cover of this document.

It assumes the reader is familiar with the basic operating and programming knowledge of Murata Wiedemann punch presses.

Adding the Plasma Option to a CNC turret punch press provides a system with which to cut extensive shapes and configurations without the costs associated with the purchasing and maintenance of special punches and dies. It also allows an increase in cutting speeds, while providing smoother cuts over longer lengths.

2.1 Dimensions

All dimensional data in this document are in English and Metric. In most cases Inch references are stated first, followed by metric in parenthesis. In some cases, such as example programs, the programs and diagrams are given twice (for clarity and ease of reading), once in english and once in metric.

3.0 TORCH LOCATIONS

Torch locations are not the same on all machines. Torch locations for each machine configuration is explained later on in this section.

3.1 C3000

Refer Figure 1-1.

The torch on the C3000 machine is directly in front of the main punch. The center-line of the cutting torch is located 9.843" (250mm) forward of the primary punching head. When Plasma statements are used an offset is automatically input to the "Y" axis, allowing the programmer to use the same references for Punching and Plasma. The burning window for the Y axis is 50.196" (1275mm).

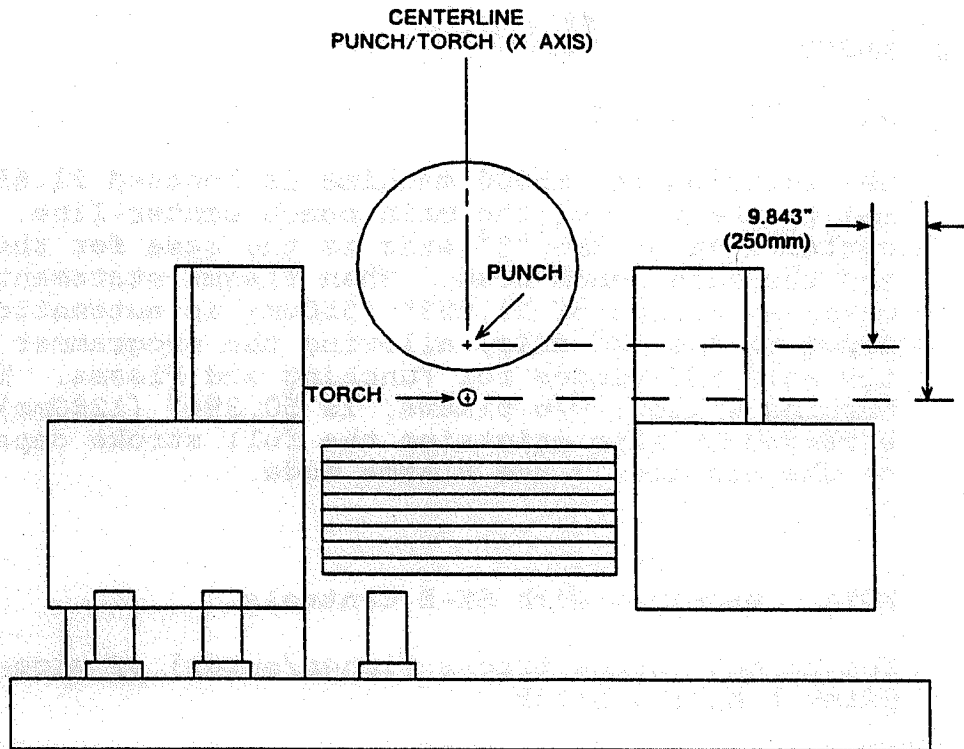

FIGURE 1-1 C3000 TORCH LOCATION

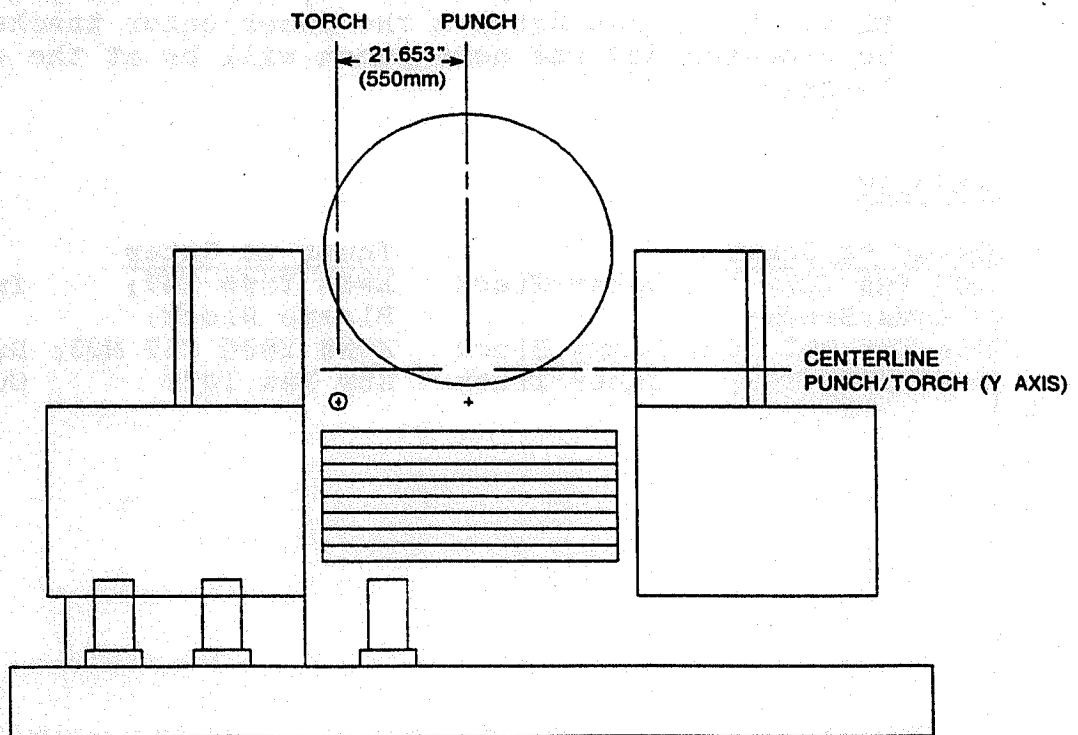

FIGURE 1-2 M5000 TORCH LOCATION

3.2 M5000

Refer Figure 1-2.

The torch on the M5000 machine is located 21.653" (550 mm) to the left of the main punch center-line. The center-line of the "Y" axis is the same for the torch and the main punch head. When Plasma statements are used, an offset of 21.653" (550mm) is automatically input to the "X" axis, allowing the programmer to use the same references for Punching and Plasma. The burning window, w/o plasma, is 50.394" (1280mm). This arrangement also maintains the full stroke capabilities of the machine in the Plasma mode.

NOTE: Machines with 6M-B Controls.

You cannot change tracks (inner/outer) or vice-versa after a plasma block

UNLESS

you first program a "Dummy" block, corresponding to the last track used prior to the plasma block, using the same tool location, followed by a M03. If you do not do this, the offset between the inner/outer tracks will not be executed and the next punch will be at the wrong location.

EXAMPLE

<u>Outer to Inner</u>		<u>Inner to Outer</u>	
X## Y## T07;	Outer Track	X### Y### T47;	Inner Track
Plasma Block;		Plasma Block;	
X## Y## T07 M03;	Dummy Block	X### Y### T47 M03;	Dummy Block
X### Y### T47;	Inner Track	X## Y## T07;	Outer Track

1.0 GENERAL

Programming of the torch, from a programmers point of view, is basically the same for the torch as it is for the punch. The exceptions are the workholder zones and the commands which initiate the plasma mode and determine the direction of kerf offset.

2.0 WORKHOLDER SAFETY ZONES

Refer Figure 2-1.

<u>MACHINE</u>	<u>ZONE</u>
C3000	X = 6.34in (161mm) each side Y = 5.12in (130mm)
M5000	X = 7.40in (188mm) each side Y = 5.35in (136mm)

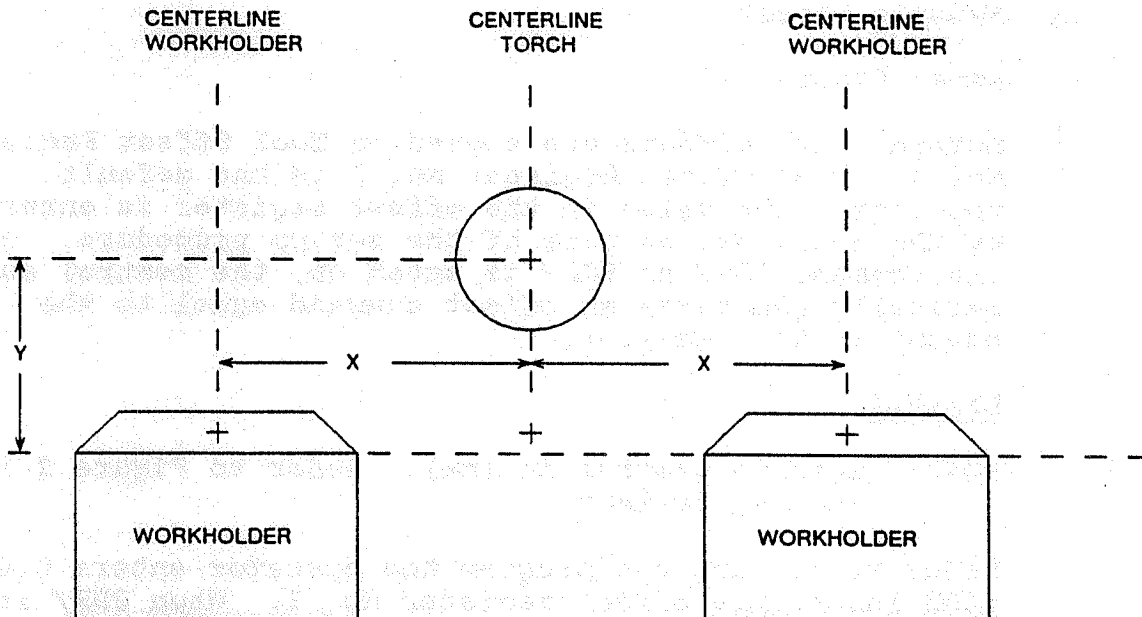

FIGURE 2-1 WORKHOLDER SAFETY ZONE DIAGRAM

3.0 KERF OFFSET

A variable amount of material is dissipated during Plasma cutting. The width of the material dissipated is referred to as "Kerf" or "Kerf Width". The kerf width is dependent on several variables, which includes, but is not limited to; Material types and thicknesses; Gas mixtures and pressures, and cutting speeds. Therefore, to produce a finished piece part to required accuracies, we must be able to compensate for the kerf width.

Kerf offsets are controlled through the use of the CNC "Offset" registers. These registers are accessed by the PDR/ and PDL/ commands.

The amount of offset entered into an offset register is determined by "experience data" developed by each user.

The direction of offset is coded in the third letter of the Plasma start commands;

- Offset to the RIGHT of programmed path = PDR
- Offset to the LEFT of programmed path = PDL

NOTE: Maximum kerf offset is 1.57" (40mm). If this amount is exceeded ERROR ALARM #041 (OFS-C) will be generated.

3.1 Example Offset

Refer Figure 2-1.

Cutting path offsets are stored in Tool Offset Register No. 1. Tool Offset Register No. 1 is the default register. The value in the offset register is entered by the operator, as part of the set-up procedure. When the command PDR/ or PDL/ is acted on, the control automatically generates an offset command equal to the amount in the register.

EXAMPLE

NOTE: Example program in (mm). Refer to Figure 2-1 for inch equivalent.

Prior to running the program the operator enters 0.0039" (0.10mm) into offset register No. 1. When PDR/ is acted on the table is offset 0.0039" (.1mm) to the left (the cutting path is shifted 0.0039" (.1mm) to the right of the programmed cutting path).

3.1 Example Offset (Continued)

```

PDR/ X50 Y50 F150 ; - - - - - A      Programmed
OFS/ DY10; (This is generated by PDR/)
X150 Y100 ; - - - - - B      Programmed
X300 Y180 ; - - - - - C      Programmed
  
```

Note the actual center-line of cut is offset to the right of the programmed center-line of cut (as viewed into the direction of travel).

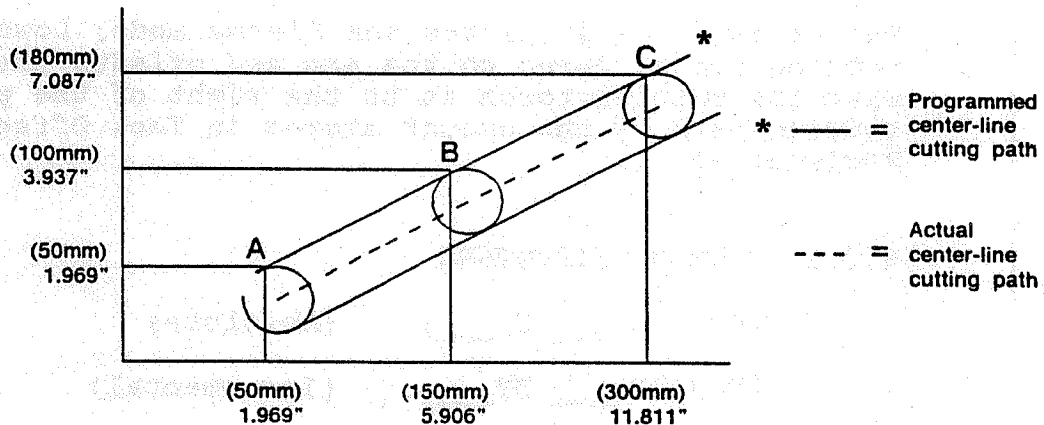

FIGURE 2-2 KERF OFFSET RIGHT (PDR/)

4.0 PLASMA COMMANDS

Plasma operation is controlled by three (3) basis geometric commands:

- PDL
- PDR
- PED

4.1 PDL

The command PDL initiates the Plasma mode; Lowers the cutting torch; Turns on the arc and offsets the table so that the cutting torch is to the left of the programmed cutting path by the amount stored in Tool Offset Register No. 1.

4.1.1 COMMAND STRUCTURE

PDL/ X____ Y____; (Absolute)

PDL/ DX____ DY____; (Incremental)

4.2 PDR

The command PDR initiates the Plasma mode; Lowers the cutting torch; Turns on the arc and offsets the table so that the cutting torch is to the right of the programmed cutting path by the amount stored in Tool Offset Register No. 1.

4.2.1 COMMAND STRUCTURE

PDR/ X____ Y____; (Absolute)

PDR/ DX____ DY____; (Incremental)

4.3 PED

NOTE: PED/ must be programmed with a coordinate and mode (absolute/incremental) which will not result in table movement. e.g. PED/X40 or PED/DX0.

The command PED turns OFF the Plasma mode; Turns OFF the arc; Cancels the offset generated by PDL/PDR and raises the cutting torch.

4.3.1 COMMAND STRUCTURE

PED/ X____ Y____; (Absolute)

PED/ DX____ DY____; (Incremental)

5.0 CUTTING (TABLE) FEEDRATES

Cutting feedrates will vary, depending on (not limited to); material thickness; material type; gas pressures, purities etc; adjustments and ambient environmental conditions. Actual rates used for each application must be determined by experimental cutting at each facility.

6.0 MOTION COMMANDS

6.1 Linear Command

X____ Y____; (Absolute)

DX____ DY____; (Incremental)

6.2 Circular Commands

6.2.1 CIR (Circle)

This command is used to program circles and/or arcs when the coordinates of the arc center are known.

The center of the circle or arc is stated in X-Y coordinates. The length of the arc is stated in degrees, from the start point. Direction (CW) is indicated by the presence of a minus (-) preceding the angle. Direction (CCW) is indicated by the absence of a minus (-) preceding the angle.

6.2.2 COMMAND STRUCTURE

CIR/ x y θ

x y = Arc center coordinates

θ = Degrees of arc (from start point)

6.2 Circular Commands (Continued)

6.2.3 EXAMPLES

Inch

A = Start Point
B = Arc Center

X78.740 Y60.039 M02

(A) X19.685 Y19.685;
(B) CIR/ 15.748 19.685 90

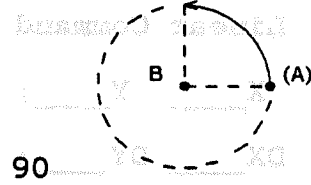

X78.740 Y60.039 M02;

(A) X19.685 Y19.685;
(B) CIR/ 15.748 19.685 -90;

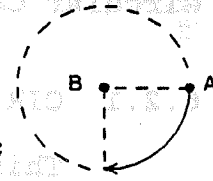

Metric

A = Start Point
B = Arc Center

X2000 Y1525 M02

(A) X500 Y500;
(B) CIR/ 400 500 90

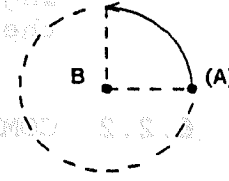

X2000 Y1525 M02;

(A) X500 Y500 ;
(B) CIR/ 400 500 -90;

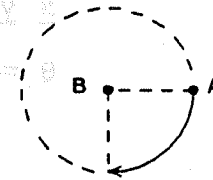

7.0 M5000 TRACK CHANGES

NOTE: M5000 machines with dual tracks and 6M-B Controls !

To change tracks immediately following a plasma operation, a "Dummy Block" (same as the last punching block prior to plasma) followed by an M03 must be inserted, prior to, the first punching block, following a plasma operation.

If this procedure is not followed the punch location, following plasma operation, will be incorrectly located.

EXAMPLE

<u>Outer to Inner</u>			<u>Inner to Outer</u>	
X## Y## T07;	Outer Track		X### Y### T47;	Inner Track
Plasma Block;			Plasma Block;	
X## Y## T07 M03;	Dummy Block		X### Y### T47 M03;	Dummy Block
X### Y### T47;	Inner Track		X## T07;	Outer Track

SAMPLES

1.0 SAMPLE PROGRAM (Inch)

Note: Metric Feedrate = .1 X Inch Mode Feedrate

** NOTE-1: Enter a work coordinate offset (OFS/X___Y___) sufficient to leave a scrap border on the end locator side (X), and workholder clearance in the (Y), suitable for your model of machine and material size. Load block will vary with optional table sizes.

<u>LINE #</u>	<u>COMMAND</u>	<u>DESCRIPTION</u>
1	X72.047 Y60.039 T15 M00; X78.740 Y60.039 T15 M00;	Load Position (M5000) (C3000)
**	See note-1	
2	MOV/X12 Y10;	Center of Circle
3	BHC/8 180 12;	Bolt Hole Circle
4	PDL/X12+.8 Y16-.8 F2000;	(Point "A")
5	X12 Y16;	(Point "A" to "B")
6	CIR/12 10 360;	(Point "B")
7	DX-.8 DY-.8;	(Point "B" to "C")
8	PED/DX0 DY0;	(See Notes)
9	DX -21.653 M00;	(Remove Slug)
10	PDR/X20-.8 Y-.6 F2000;	(Point "D")
11	DX4.8 DY3.6;	(Point "D" to "E")
12	Y20;	(Point "E" to "F")
13	X4;	(Point "F" to "G")
14	CIR/4 16 90;	(Point "G" to "H")
15	Y0;	(Point "H" to "J")

1.0 SAMPLE PROGRAM (Inch) (Continued)

<u>LINE #</u>	<u>COMMAND</u>	<u>DESCRIPTION</u>
16	X20;	(Point "J" to "K")
17	PED/DX.1;	(Ends Cutting)
18	DX -21.653 M00;	(Remove Piece Part)
19	OFS/X0 Y0;	(Remove Offset)
20	M99;	(Return head of program)

1.1 Sample Program Description

Line-1 Self explanatory.

Line-2 Self explanatory.

Line-3 Bolt Hole Circle statement. At a radius of 8" (200mm) (from present position), punch 12 holes, starting at 180°.

Line-4 (Point "A")

The ABSOLUTE coordinate at which the cut is to start. The PDL command puts the machine in the Plasma mode, offsets all data points (in the X or Y axis, depending on the machine type) and determines that Kerf compensation will be on the left of the cutting path.

Line-5 (Point "A" to "B")

Cut from the present position to an ABSOLUTE position of X12" (300mm) Y16" (400mm). This command ignites the torch in the slug area, assuring a smooth transition into the piece part.

NOTE: Where practical, the torch should always be ignited prior to starting the cut of the actual part. Likewise, extinguish the torch after cutting out of the piece part.

Line-6 (Point "B")

Cut from the present position (point "B") a circle of 360°, in the CCW direction (CCW determined by absence of a minus sign).

1.1 Sample Program Description

Line-7 (Point "B" to "C")

Cut from the present position (In INCREMENTAL mode) a move of X-.8 (20mm) Y-.8" (20mm). Turn OFF the torch and exit Plasma mode. This cut assures a smooth transition out of the piece part.

Line-8 PED/ must be programmed with a coordinate and mode (absolute/incremental) which will not result in table movement. e.g. PED/X1.6" (40mm) or PED/DX0.

PED/ will cancel plasma mode, remove offset and raise the torch. No table movement will occur.

Line-9 Programmed stop to allow removal of circular slug.

Line-10 (Point "D")

Selects Plasma mode, Kerf compensation to the right of the cutting head and positions to point "D".

Line-11 (Point "D" to "E")

In the Incremental mode, cut from the present position Point "D", to X5" (120mm) Y3.5" (90mm) (point "E").

Line-12 (Point "E" to "F")

From the present position (point "E"), cut to an ABSOLUTE position of Y20" (500mm). (Note no change in X coordinate.)

Line-13 (Point "F" to "G")

From the present position (point "F") cut to an ABSOLUTE position of X4" (100mm). (Note no change in Y coordinate.)

Line-14 (Point "G" to "H")

Cut from the present position, an ARC of 90°, in the CCW direction. The arc-center is located at X4" (100mm) Y16" (400mm).

1.1 Sample Program Description (Continued)

Line-15 (Point "H" to "J")

In the Absolute mode, cut from the present position to Y0.

Line-16 (Point J to K)

In the Absolute mode, cut from the present position to X20" (500mm). Turn off the arc and raise the cutting head.

Line-17 Remove slug

Line-18 Programmed stop. Remove piece part.

NEVER use DWELL commands to allow an operator interference operation! e.g. to remove slugs, slag, or piece parts.

Line-19 Remove work coordinate offsets.

Line-20 Return to the head of the program.

Line-11 (Point "D" to "R")

In the Incremental mode, cut from the present position point "D" to XR" (110mm) Y1.2" (30mm) (point "E").

Line-12 (Point "E" to "F")

From the present position (point "E"), cut to an ABSOLUTE position of Y10" (100mm). (Note as change in X coordinate.)

Line-13 (Point "F" to "G")

From the present position (point "F") cut to an ABSOLUTE position of X4" (100mm). (Note as change in Y coordinate.)

Line-14 (Point "G" to "H")

Cut from the present position, an ARC of 90° in the CCW direction. The arc-center is located at X4" (100mm) Y18" (400mm).

1.2 Sample Program Piece Part (Inch)

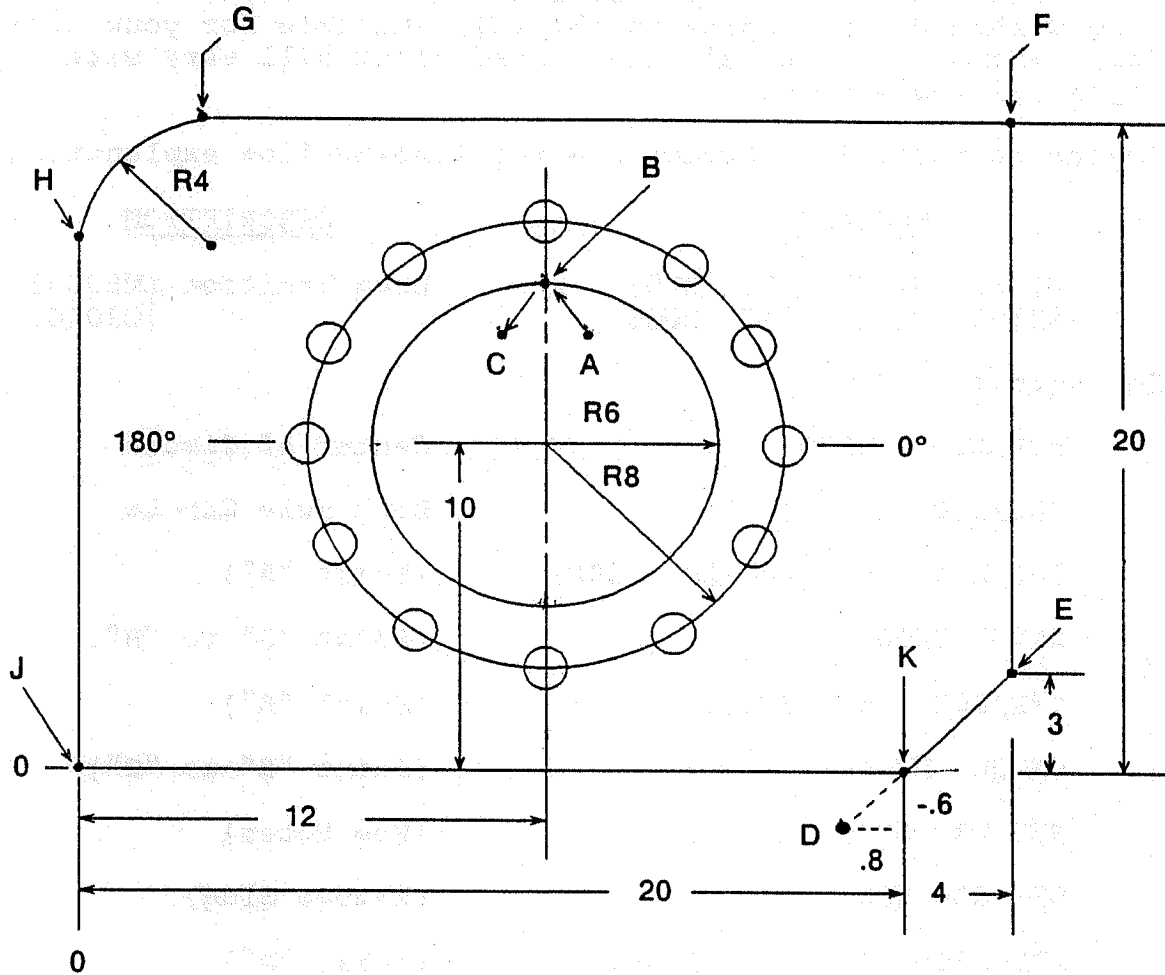

FIGURE 3-1 SAMPLE PIECE PART (Inch)

2.0 SAMPLE PROGRAM (Metric)

Feedrates are programmed in Centimeters

** NOTE-1: Enter a work coordinate offset (OFS/X___Y___) sufficient to leave a scrap border on the end locator side (X), and workholder clearance in the (Y), suitable for your model of machine and material size. Load block will vary with optional table sizes.

Refer to pages 3-2 through 3-4 for line-by-line explanation.

<u>LINE #</u>	<u>COMMAND</u>	<u>DESCRIPTION</u>
1	X1830 Y1525 T15 M00; X2000 Y1525 T15 M00;	Load Position (M5000) (C3000)
**	See note-1	
2	MOV/X3000 Y250;	Center of Circle
3	BHC/200 180 12;	Bolt Hole Circle
4	PDL/X300+20 Y400-20 F508;	(Point "A")
5	X300 Y400;	(Point "A" to "B")
6	CIR/300 250 360;	(Point "B")
7	DX-20 DY-20;	(Point "B" to "C")
8	PED/DX0 DY0;	(See Notes)
9	DX -550 M00;	(Remove Slug)
10	PDR/X500-20 Y-15 F508;	(Point "D")
11	DX120 DY90;	(Point "D" to "E")
12	Y500;	(Point "E" to "F")
13	X100;	(Point "F" to "G")
14	CIR/100 400 90;	(Point "G" to "H")
15	Y0;	(Point "H" to "J")
16	X500;	(Point "J" to "K")
17	PED/DX2.54;	(Ends Cutting)
18	DX -550 M00;	(Remove Piece Part)
19	OFS/X0 Y0;	(Remove Offset)
20	M99;	(Return head of program)

CHAPTER FOUR

PLASMA ALARMS

1.0 PLASMA ALARM LIST

<u>ALARM #</u>	<u>DESCRIPTION</u>	<u>CONDITION</u>
2080	PLASMA ERROR	TORCH UP" or "TORCH DOWN" was not completed. Torch Up (DGN 20.3=1) Torch Down (DGN 20.5=1)
1081	TORCH NOT UP	Axes movement W/O plasma was attempted.
1082	PLASMA NOT READY	Cleaner off or toggle switch not in "main" position during plasma cycle.
1084	CLAMP UNDER ARC	A command was given to cut within the plasma safety zone.
1086	PLASMA INTERLOCK	"Chute Up" or "Chute Short Up" not detected during plasma cycle. Axes movement W/O plasma was attempted.
2180	PLASMA HAND MODE	Plasma cycle started in hand mode.
2098	TRAVEL GUIDE NOT SET	Travel guide is not set. Travel Guide Set (DGN 3009.4 = 1)
1099	SLUG BOX NOT SET	Slug box is not set. Slug box set (DGN 3009.3 = 1)