

MURATA MACHINERY, LTD.

MURATA MACHINERY, LTD.

Logistics & Automation Division
International Marketing & Sales Dept.
Green-Bldg. 7F, 2-6-26, Kitahama, Chuo-ku, Osaka, 541-0041, JAPAN
TEL: +81-(0)6-6202-1387 FAX: +81-(0)6-6202-1388

MURATA MACHINERY USA, INC.

Logistics & Automation Division
2120 Queen City Drive, P.O.Box 667609, Charlotte, N.C. 28208, U.S.A.
TEL: +1-704-394-6900 FAX: +1-704-394-2001
<http://www.muratec-usa.com/>

Salt Lake City Office

120 North Redwood Road Suite 3 North Salt Lake, UT 84054, U.S.A.
TEL: +1-801-683-3500 FAX: +1-801-683-3501

MURATA MACHINERY EUROPE GMBH

Dresden Branch
Moritzburger Weg 67 Bruno Paul Haus 01109, Dresden, GERMANY
TEL: +49-(0)351-883-8473 FAX: +49-(0)351-883-8475

MURATEC AUTOMATION EUROPE SARL

Everdyn Technologies Center
190 Chemin des Fontaines, Parc Technologique des Fontaines,
Bermin - 38926 Crolles Cedex - France
TEL: +33-(0)4-7604-1598 FAX: +33-(0)4-2699-9535

MURATA MACHINERY (SHANGHAI) CO., LTD.

[Registry Add]
130 Fu Te Xi Yi Rd., Wai Gao Qiao Free Trade Zone, Pudong Shanghai, CHINA
[Contact Add]
150 Xin Gao Rd., Qingpu Industrial Zone, Shanghai, 201700, CHINA
TEL: +86-(0)21-6921-2300 FAX: +86-(0)21-6921-2311

MURATA MACHINERY TAIWAN, LTD.

TAIPEI OFFICE
18F., No.17, Sec.1, Chengde Rd., Taipei 10351, Taiwan, CHINA
TEL: +886-(0)2-2558-5505 FAX: +886-(0)2-2558-6606

HSIN-CHU SERVICE CENTER

1F., No.3 Lane 216 Gongyuan Rd., Hsin Chu City, 30069, Taiwan, CHINA
TEL: +886-(0)3-561-0508 FAX: +886-(0)3-561-0515

TAINAN SERVICE CENTER

1-2F., No.968, Gongyuan Rd., Tainan 70446, Taiwan, CHINA
TEL: +886-(0)6-281-1381 FAX: +886-(0)6-281-1289

TAIWAN TECHNICAL CENTER

No.432, Dunhua Rd., Beitun District, Taichung City 40678, Taiwan, CHINA
TEL: +886-(0)4-2292-2325 FAX: +886-(0)4-2292-3515

MURATA MACHINERY SINGAPORE PTE. LTD.

30 Loyang Way #05-17/18
Loyang Industrial Estate, SINGAPORE 508756
TEL: +65-6545-1228 FAX: +65-6545-2221

* All specifications are subject to change without advance notice.

USB01E 11A-1-1(FR-SG)

Uni-SHUTTLE HP

High Performance
Automated Storage / Retrieval System



MURATA MACHINERY, LTD.

High Performance Automated Storage / Retrieval System

Uni-SHUTTLE HP

Uni-SHUTTLE HP is an automated storage / retrieval system designed to provide best-in-class capacity and performance through a combination of flexible storage functionality and high-capacity transport and sorting capabilities.

The requirements for handling loads of various sizes, the need for high-throughput operations, and the demand for small-lot production for just-in-time operations and same-day delivery drive the need for new technology. Retaining operators in this difficult era of recruiting workers also demands new ideas in automation. Uni-SHUTTLE HP is the solution to these challenges.

The rack system can store loads of various sizes and shapes to achieve high-capacity storage. A high-speed shuttle runs independently on each level to minimize transport times. These features, along with the ability to perform either sequential or group retrievals, combine to provide the optimum in high-performance and flexibility.

Features

Flexibility

Storage in various locations

The flat-rack type enables the storage of carton cases, folding containers, buckets and other cases in flexible locations inside the rack.

Handling of various size loads

From 4 to 7 loads are efficiently stored in each storage cell. The transfer equipment of the shuttle vehicle handles all these various load sizes.

High capacity, high quality and high reliability

High-speed group retrieval

The combination of the shuttle vehicle to independently travel at each level and the "Space Storage" can carry out group retrieval for each delivery destination and each customer.

High-speed group / sequential retrieval

The combination of the shuttle and "Vertical Conveyor" can carry out high-speed retrieval of a large quantity of goods. It can also easily carry out sequential retrieval as the situation requires.

Best-in-class storage and retrieval capacity

Max. 3,000 cases / hour

Where Space Storage is selected as the storage and retrieval equipment, it provides the best-in-class storage and retrieval capacity for a maximum of 3,000 cases per hour.

Flexible layout

Several Vertical Conveyors can be combined to make up the storage and retrieval equipment. These are effective for the simultaneous delivery to many areas.

System configuration

Flexible Rack Locations

The free-rack type enables flexible and efficient handling of various load sizes.



Vertical Conveyor

With a hoisting speed of 120 m/min the Vertical Conveyor can store and retrieve up to 900 cases per hour. The Vertical Conveyor can be installed on any of the four sides of the rack for maximum flexibility.



Space Storage

Continuously stores / retrieves a large quantity of loads at the same time. The high-speed storage / high-speed dispatch of a maximum of 1,500 cases per hour can be achieved.



Maintenance deck

The maintenance deck in the rack facilitates the maintenance and trouble shooting work.



Shuttle vehicle

The shuttle vehicle travels at the high speed of 400 m/min. The transfer equipment is of the rear hook type, therefore it handles various load sizes. The average transfer time is 3.5 seconds. It travels independently on each level. Therefore, trouble recovery is easy.

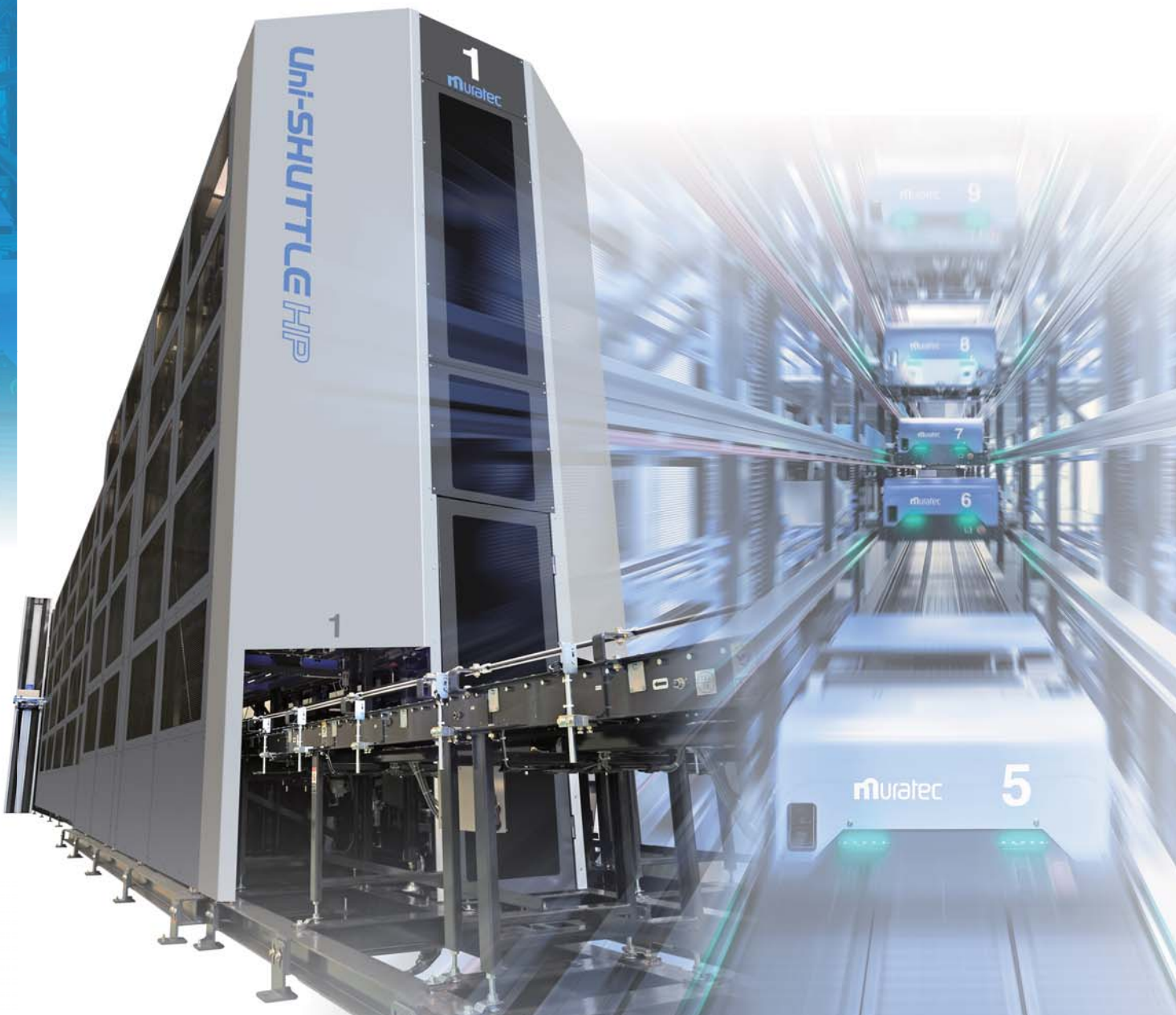

Best-in-class storage and retrieval capacity

High-capacity storage / retrieval of 3,000 cases / hour

Space Storage is installed on both the storage side and retrieval side.

Through the combination of Space Storage to continuously store / retrieve a large quantity of loads at the same time and the high-speed shuttles that travel independently on each level, a wide variety of goods received at the same time can be efficiently stored and sorted, and group retrieval can be carried out at high speed.

Storage capacity of Space Storage: 1,500 cases / hour + Flexible rack locations / 10 shuttles + Retrieval capacity of Space Storage: 1,500 cases / hour

Automated replenishment and sortation
Optimized picking and sorting by fixed-position workers



For site where many mobile pickers are required:

A wide variety and large quantity of loads are automatically stored by Space Storage and replenished to various locations within the rack. Group retrieval can be performed at high-speed by Space Storage. This allows fixed-position workers to perform efficient picking operations, realizing space and labor-saving benefits.

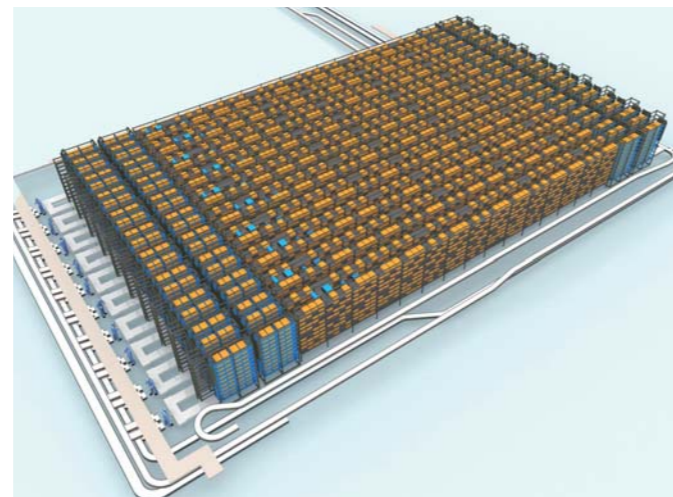

Flexible system configuration

The capacity of sorting for multiple areas is provided.

Space Storage is used for storage, and several Vertical Conveyors are used for retrieval.

Space Storage continuously stores a large quantity of loads at the same time, the high-speed shuttle travels independently on each level, and several Vertical Conveyors carry out group / sequential retrieval.

Storage capacity of Space Storage: 1,500 cases / hour + Flexible rack locations / 10 shuttles + Retrieval capacity of Vertical Conveyor: 750 cases / hour

Retrieval capacity of Vertical Conveyor: 750 cases / hour

Automated replenishment and sortation
Simultaneous retrieval to multiple stations

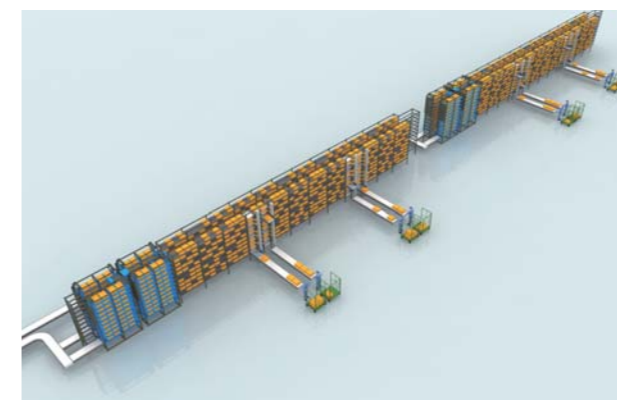
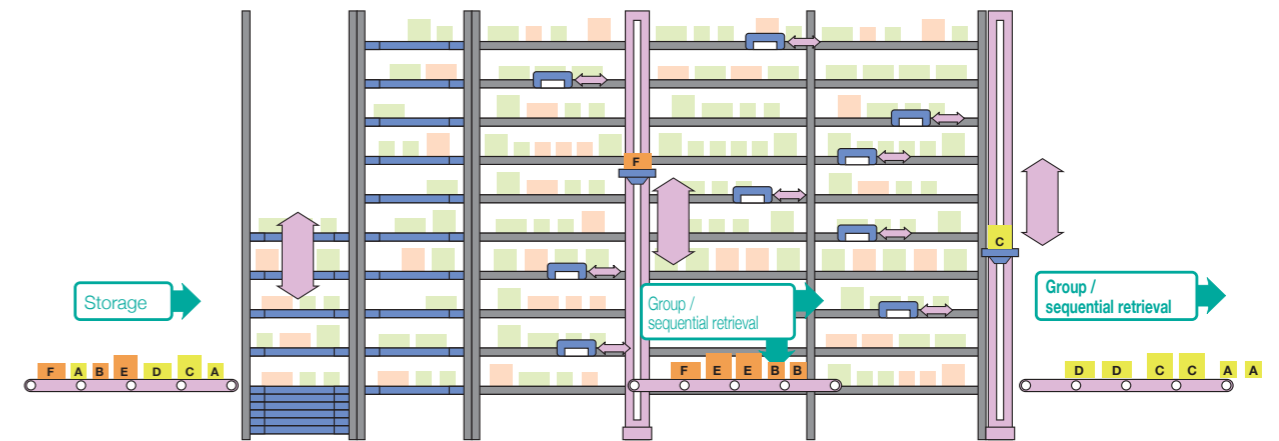

For a Distribution Center where sorting and delivery of many goods for many customers is required:

Space Storage continuously stores a large quantity of loads at the same time. The combination of the high-speed shuttles that travel independently on each level and several Vertical Conveyors enables group / sequential retrieval at high speed at each station. Space-saving sorting can also be carried out.

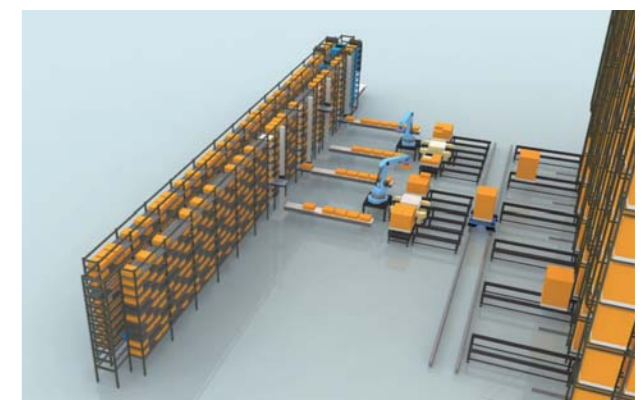

For sorting and dispatch in a factory where simultaneous production of a wide variety of goods is required:

Utilizing the combination of simultaneous and continuous storage by Space Storage, the rack for storage in various locations, and several Vertical Conveyors, the system can carry out sorting and dispatch of goods prior to palletization.

Transport equipment

Shuttle vehicle

The Shuttle vehicle travels at the high speed of 400 m/min. The transfer equipment is of the rear hook type, therefore it handles various load sizes and gently transfers loads. The average transfer time is 3.5 seconds. The energy-saving design uses regenerative power to reduce power consumption by a up to of 30%. Maintenance can be carried out on the maintenance deck, and the vehicle can be lowered down by using the chain block set on the position opposite the home side of the rack.

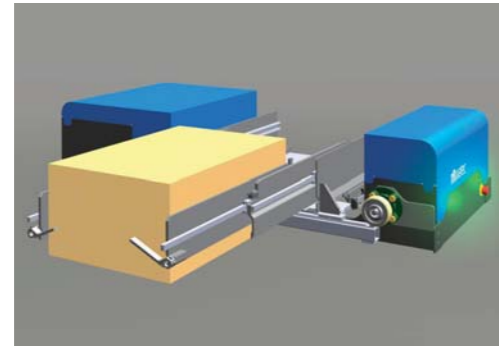

Traveling speed (m/min)		Max. 400	
Transfer equipment		Rear hook type	
Load transfer speed (m/min)		Max. 60	
Clamping speed (m/min)		Max. 7.5	
Load transfer time (sec)		Average 3.5	
Load size (mm)	Maximum	W	450
		D	600
		H	600
	Minimum	W	175
		D	225
		H	90
Load weight (kg)	Maximum	25	
	Minimum	1	



Space Storage

Space Storage continuously stores / retrieves a large quantity of loads at the same time. It can hold 40 cases as a buffer and can carry out high-speed storage / high-speed dispatch of up to 1,500 cases per hour.

Hoisting spec. (m/min)		Max. 20 (Chain drive)	
Conveyor spec. (m/min)		Max. 40 (Belt conveyor)	
Storage quantity (cases)		40 cases (4 cases / level x 10 levels)	
Load size (mm)	Maximum	W	450
		D	600
		H	600
	Minimum	W	175
		D	225
		H	90
Load weight (kg)	Maximum	25	
	Minimum	1	

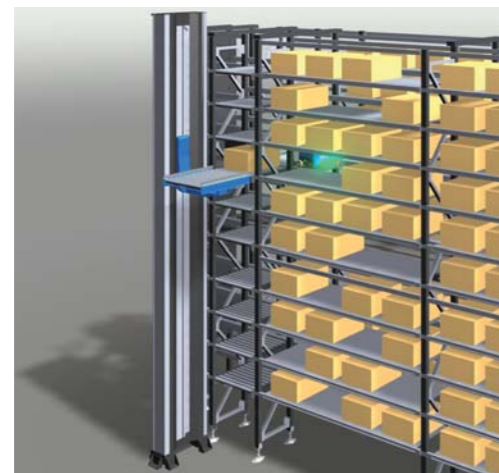

Vertical Conveyor

The hoisting speed is 120 m/min and it can store / retrieve up to 900 cases per hour. It can be flexibly installed in the front, rear, right or left side of the rack, and can carry out fixed-point picking for delivery to many areas and to other operations.

Hoisting spec. (m/min)		Max. 120	
Conveyor spec. (m/min)		Max. 30 (Roller conveyor)	
Load size (mm)	Maximum	W	450
		D	600
		H	600
	Minimum	W	175
		D	225
		H	90
Load weight (kg)	Maximum	25	
	Minimum	1	

Reference system configuration

4 Space Storage units configured together can handle storage / retrieval of up to 1,500 cases per hour. The rack contains 10 levels x 5 bays and stores a maximum of 700 cases. This capacity can be achieved through a space-saving 50-square-meter floor area.

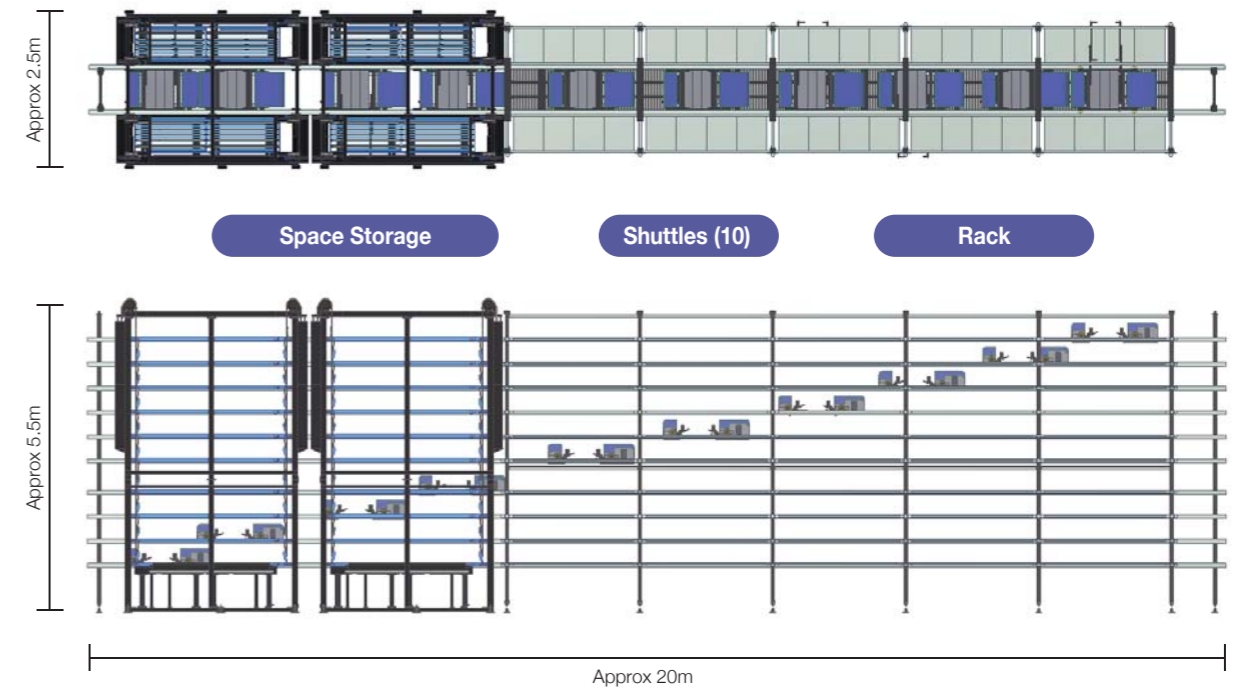

Rack	Number of cells	2 rows x 5 bays x 10 levels
	Storage quantity	2 rows x 5 bays (x 7 cases) x 10 levels = 700 cases *1,2
Shuttle vehicle		10
Space Storage	Spec.	10 levels, 2 units for storage, 2 units for retrieval
	Storage capacity (cases/ hr)	1,500
	Retrieval capacity (cases/ hr)	1,500
Installation space (m)	L	Approx 20
	W	Approx 2.5
	H	Approx 5.5

*1. When 7 loads are stored, load width is between 250mm and 175mm.

*2. Not including the Space Storage capacity

* Capacities of storage / retrieval / transport are depended on system configuration and operation.