

Max Station Range	1/2" Round Only	1/2"	1 1/4"	2.00"	3 1/2"	4 1/2"	Auto Index	
							1 1/4"	2.000"
Act. Station Range								
No. of Stations	5	13	8	2	2	N/A	2	1
Round/Oround	.500" Rnd. ONLY	.5" & Under	.501" to 1.250"	1.251" to 2.00"	2.001" to 3.500"	3.501" to 4.500"	.501" to 1.250"	1.251" to 2.00"
Square	N/A	0.353"	0.883"	1.414"	2.474"	3.125"	0.883"	1.414"
Rectangle	N/A	0.500" Across Corners	1.250" Across Corners	2.000" Across Corners	3.500" Across Corners	4.500" Across Corners	1.250" Across Corners	2.000" Across Corners
Punch Holder O.D.	1.019"	1.019"	1.883"	2.750"	4.374"	5.250"		
Die Holder I.D.	1.000"	1.000"	1.875"	3.500"	4.938"	6.250"		

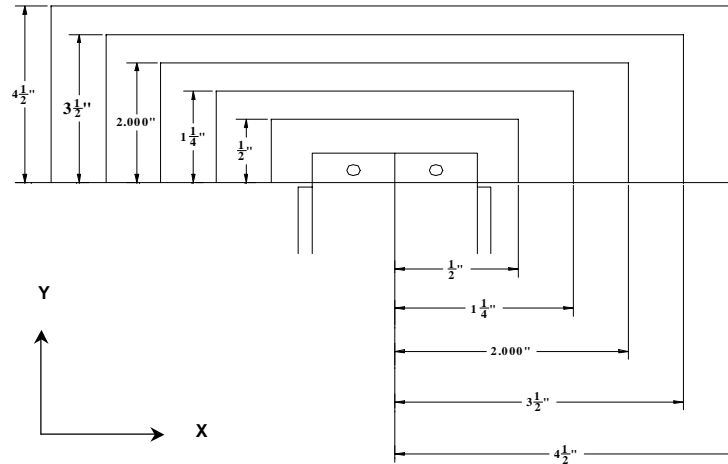
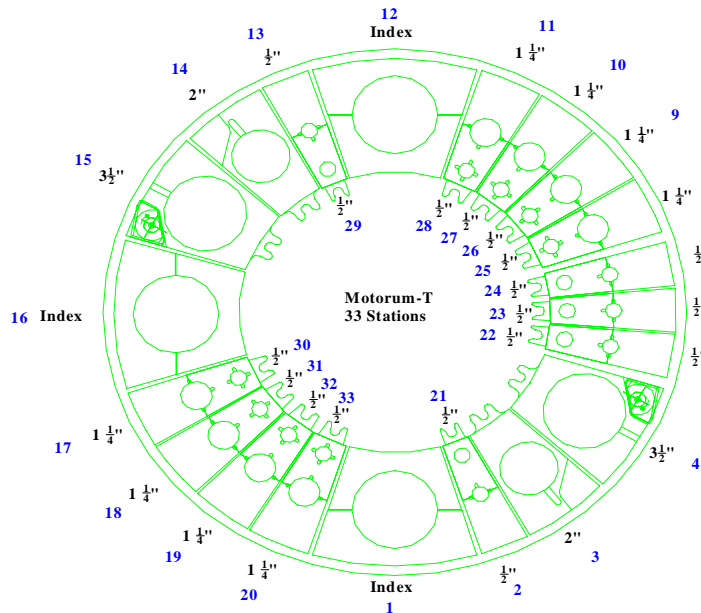

Safety Zones:	X	Y	(US) Tonnage Limits:
0.500"	+/-2.125"	0.945"	Machine: 22
1.250"	+/-2.559"	1.378"	Auto Index: 16.5
2.000"	+/-2.992"	1.811"	
3.500"	+/-3.819"	2.638"	
4.500"	+/-4.252"	3.070"	
Cell Ready add +/-0.563"			

Note: The Auto Index stations can be either 1.250" or 2.000", depending on customer requirements.

Load Position: X49.213 Y49.213 M30

Throat Depth: 52.756" (1340mm)

Over Travel: X = +/- 0.787" (20mm)

Y = + 0.197" (5mm) (Outer Track)

Y = - 2.756" (70mm) Dist. between inner & outer track (Outer track)

Y = + 2.953" (75mm) Dist. between inner & outer track, plus 5mm (Inner track)

Y = - 0 (Zero) Inner track

